



'Jyoti' CAM-OPERATED SWITCHES

Introduction

Features & Technical Specification

Ordering Instruction

Contact Sequences

Mounting Details



Unit construction system,
contact combination to suit
application

'JYOTI' Cam-Operated Switches

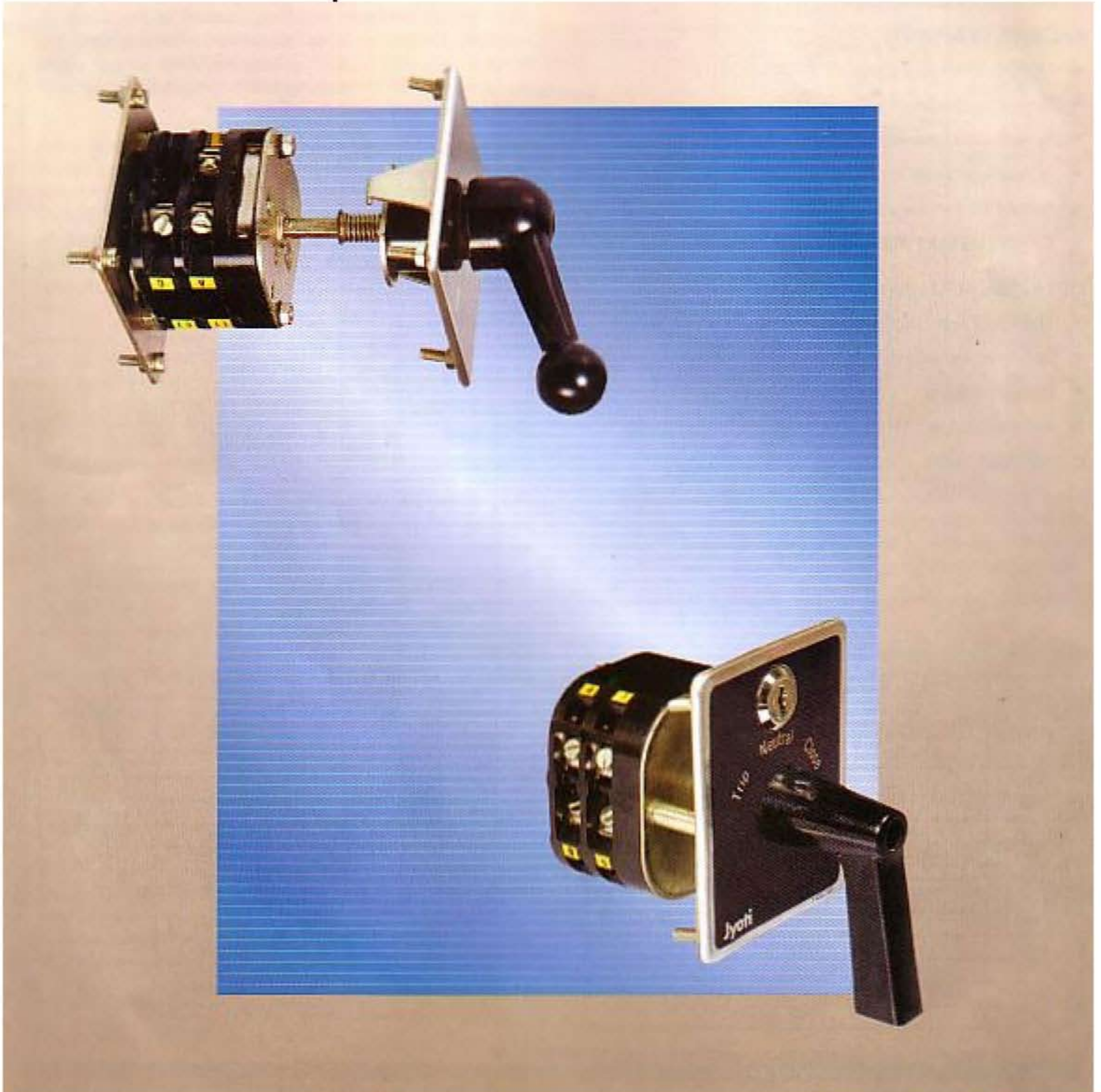

'JYOTI' CAM-OPERATED SWITCHES COMPLIES WITH IS 13947 PART III

'JYOTI' CAM-OPERATED SWITCHES are offered for wide industrial as well as domestic applications. 'JYOTI' switches are adequate for any special application, either for AC switching or DC switching, either for Load break duty operation or Motor-duty operation. The switches ensure fail-safe system operation in view of optimum component design. Over and above, the optional features make switches versatile for actual applications. 'JYOTI' switches are well accepted by Railway, L.T Control Panel manufacturers, Machine Tool Industries etc.

SALIENT FEATURES

- Unit construction system
- Rugged construction
- Selection for operating knob
- Adjustment on site for mounting plate thickness upto 5 mm.
- Special contact sequence made to order
- Contact life span equal mechanism life span

OPTIONAL FEATURES

- Door-coupling and door-interlock
- Spring return arrangement
- Position-locking
- Metal enclosure

CONSTRUCTION

A Contact chamber, moulded from high track index material, accomodates two sets of double - break contact system. Desired contact sequence can be achieved with cams moulded from wear resistant material.

Depending on application, number of contact chambers can be stacked with mechanism chamber. Mechanism chamber assembly controls operating speed during switching from one position to other. It also ensures the angle of switching.

SWITCH SELECTION FOR AC OPERATION

Current Rating at 415 V	Load Break Switches, CAT-AC-21/AC-22		Motor duty Switches CAT-AC-23/ AC-3 Type
	Standard Switch Type	Parallel Contact Switch Type	
16 A	NNA-16	—	MNA-16
25 A	NNA-25	NNA-16P	MNA-25
35 A	—	—	MNA-35
40 A	NNA-40	NNA-25P	—
55 A	—	—	MNA-55
63 A	NNA-63	NNA-40P	—
80 A	—	—	MNA-80
100 A	—	NNA-63P	—
125 A	NNA-125	—	—
200 A	NNA-200	—	—
300 A	—	NNA-200P	—

- Load Break Switches - upto 300 Amps, 415V
- Motor Duty Switches - upto 80 Amps, 415V

OPERATION

Operating device can be selected from Wing knob, Ball handle, Metal handle and Pistol-grip handle, depending on operational case. Handle indicates switching position of the switch in particular. Elegant, anodised aluminium indicating plate can be provided with switch position markings to suit user's requirements. 'JYOTI' switches can be provided with 45°, 60° or 90° switching angles.

Contact switching is independent of operating force. Cam profiles normally provide break operation of contact before make operation of other contact, while switching from one position to other. However 'JYOTI' can provide, Momentary "ON", Momentary "OFF" and Continuous "ON" contacts to match specific programme. The spring return switches in either direction can be made available for temporary contact closing.

SWITCHING ANGLES :	45°	60°	90°
MAXIMUM SWITCHING POSITION :	8	6	4

MOUNTING

The switches can be mounted on panel flush or front. The panel cut-outs required are given on the last page, The switches can be provided for rear mounting also.

Door-Coupling and door-interlock are available for complete switch range. This facilitates their utility in Motor Control Centres. Switch can also be mounted with the base of L shape clamp.

SWITCH SELECTION FOR DC OPERATION

Current Rating	110 V, DC		220 V DC 2 Pole
	1 Pole	2 Pole	
4 A	NNA1-16	—	NNA2-16
6 A	NNA1-16	—	NNA2-16
10 A	NNA1-25	NNA2-16	NNA2-25
16 A	NNA1-63	NNA2-16	NNA2-25
25 A	NNA1-63	NNA2-25	NNA2-63
40 A	NNA1-125	NNA2-25	NNA2-125
63 A	NNA1-125	NNA2-63	NNA2-125
125 A	—	NNA2-125	—
200 A	—	NNA2-200	—

The above ratings are for Dc1 CATEGORY
For other applications please contact us.

ORDERING INSTRUCTIONS FOR PROGRAMME SWITCH

BASIC	SWITCH TYPE - NNS
	Special Programme Switches
	(For Standard Switches Refer Catalogue Details) To be suffixed with
I	LOAD BREAK CURRENT RATINGS
	16 - 16A 25 - 25A 40 - 40A 63 - 63A
II	OPERATING KNOBS
	b - Wing Knob d - Ball handle k - Metal handle q - Pistol grip handle
III	SPRING RETURN SWITCHES
	R1 - One way R2 - Two way
IV	OPTIONAL FEATURES
	T - Door coupling arrangement with interlock L - Switch with lock and key H - Switch with fabricated enclosure C - Switch with rear mounting facility Z - Switch with terminal cover

- Note :1) Indicate the operating angle with cross (45°/60°/90°)
 2) Shorting links are not supplied for connecting even No. terminals to odd No.
 3) For 360° switching, mark a cross.

9	18	U	35 O	O 36	X	X		X	X		
		L	33 O	O 34	X	X		X	X		
8	16	U	31 O	O 32	X	X		X	X		
		L	29 O	O 30							
7	14	U	27 O	O 28		X					
		L	25 O	O 26	X			X			
6	12	U	23 O	O 24					X		
		L	21 O	O 22					X		
5	10	U	19 O	O 20				X			
		L	17 O	O 18				X			
4	08	U	15 O	O 16		X					
		L	13 O	O 14					X		
3	06	U	11 O	O 12				X			
		L	09 O	O 10	X						
2	04	U	07 O	O 08					X		
		L	05 O	O 06		X					
1	02	U	03 O	O 04		X					
		L	01 O	O 02					X		
Operating Angle		<input checked="" type="checkbox"/>	45°	f	g	h	a	b	c	d	e
			60°		e	f	a	b	c	d	
			90°			d	a	d	c		
Inscription Plate Marking				III	II	I	0	I	II	III	
Indicate Stopper Position 360° Switching											

ORDER PROFORMA	TYPE	I	II	III	IV						
Reference	NNS-	<input type="checkbox"/>	<input type="checkbox"/>	<input type="checkbox"/>	<input type="checkbox"/>						
Order No.	Switching Sequence Diagram										
No. Of Switching Packers	No. Of contacts	Terminal Connection	Terminal Connection	Explanation of Switching sequence Diagram.							
				<input checked="" type="checkbox"/>	Switching element closed.						
				<input checked="" type="checkbox"/>	Switching element closed without break on change over.						
				<input checked="" type="checkbox"/>	Switching element closed with break on change over.						
				<input type="checkbox"/>	<input checked="" type="checkbox"/>	Switching element closes before the other opens (Make before break)					
16	32	U	63 O	O 64							
		L	61 O	O 62							
15	30	U	59 O	O 60							
		L	57 O	O 58							
14	28	U	55 O	O 56							
		L	53 O	O 54							
13	26	U	51 O	O 52							
		L	49 O	O 50							
12	24	U	47 O	O 48							
		L	45 O	O 46							
11	22	U	43 O	O 44							
		L	41 O	O 42							
10	20	U	39 O	O 40							
		L	37 O	O 38							
9	18	U	35 O	O 36							
		L	33 O	O 34							
8	16	U	31 O	O 32							
		L	29 O	O 30							
7	14	U	27 O	O 28							
		L	25 O	O 26							
6	12	U	23 O	O 24							
		L	21 O	O 22							
5	10	U	19 O	O 20							
		L	17 O	O 18							
4	08	U	15 O	O 16							
		L	13 O	O 14							
3	06	U	11 O	O 12							
		L	09 O	O 10							
2	04	U	07 O	O 08							
		L	05 O	O 06							
1	02	U	03 O	O 04							
		L	01 O	O 02							
Operating Angle			45°	f	g	h	a	b	c	d	e
			60°		e	f	a	b	c	d	
			90°			d	a	d	c		
Inscription Plate Marking											
Indicate Stopper Position 360° Switching											

From Office	Date	Order Processor Project Engineer	Sign / Date	Project Specialist	Sign/Date
-------------	------	-------------------------------------	-------------	--------------------	-----------

CONTACT SEQUENCES

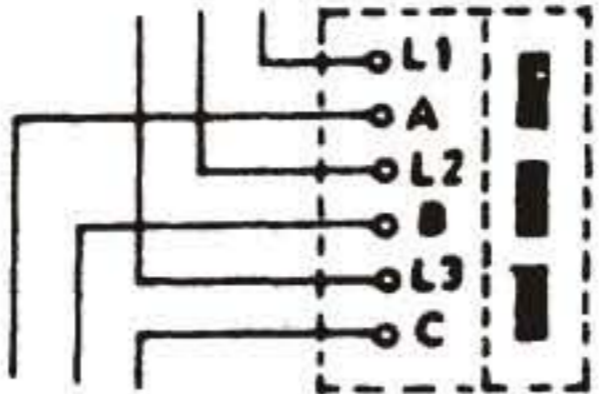
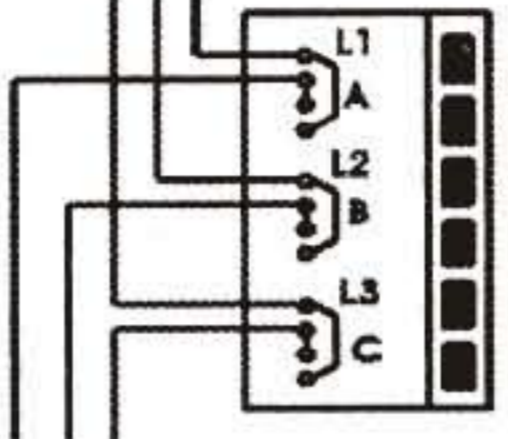
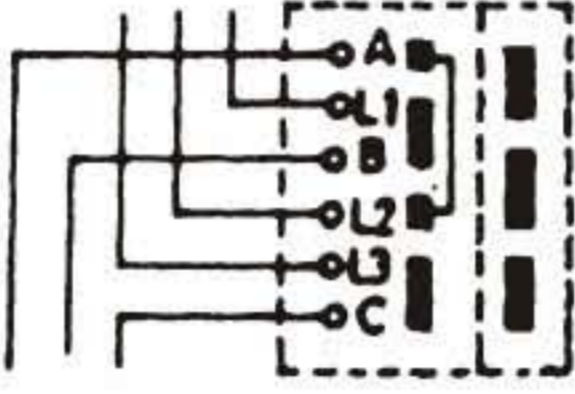
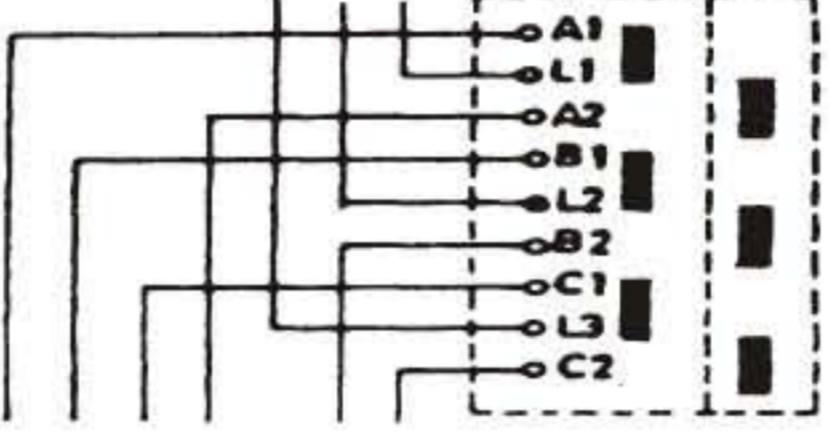
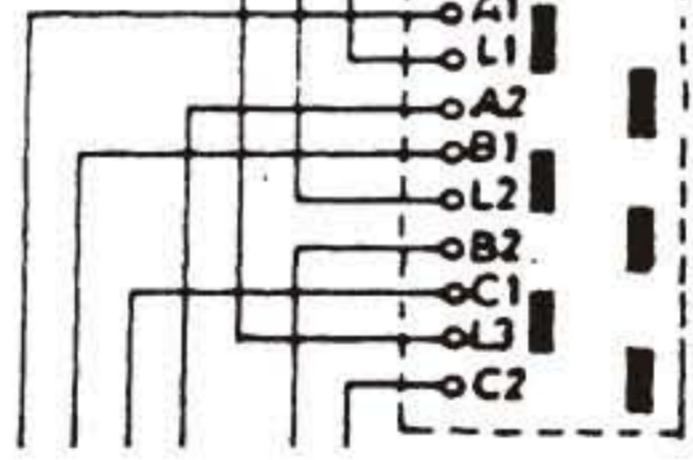
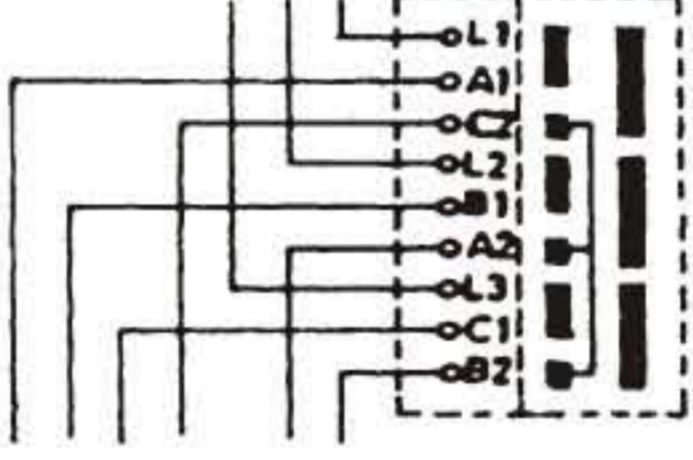
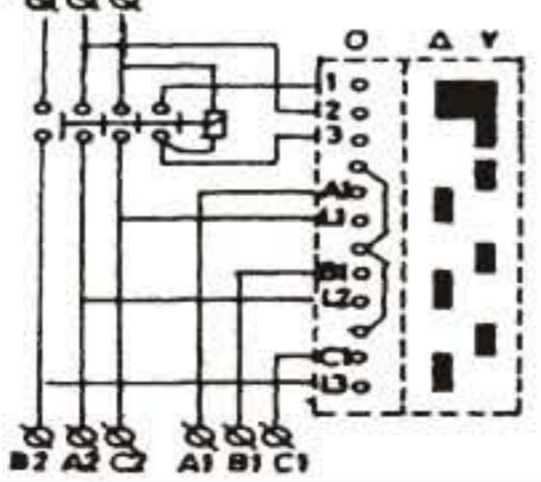
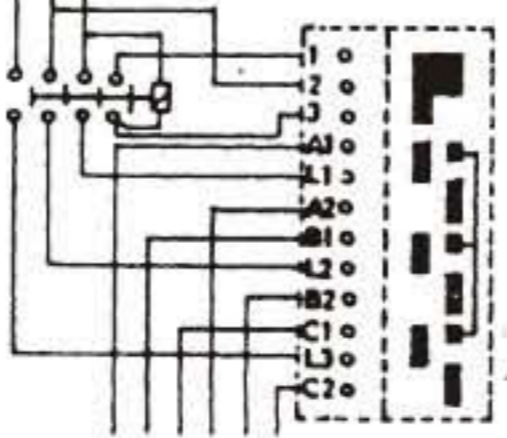
SR. NO.	DESCRIPTION	CONTACT SEQUENCES	TYPE
1. ON-OFF SWITCH- 3 POLE POSITION : 0-I SWITCHING ANGLE : 60°, 45°, 90°		NNA -16 MNA-16 NNA -25 MNA-25 NNA -40 MNA-35 NNA -63 MNA-55 NNA -125 MNA-80 NNA -200	
2. ON-OFF SWITCH PARALLEL CONTACT 3 POLE POSITION : 0-I SWITCHING ANGLE : 60°,45° ,90°		NNA -16P NNA -40P NNA -63P NNA -200P	
3. REVERSING SWITCH -3 POLE POSITION : I-0-I SWITCHING ANGLE : 60°, 45°		MNW -16 MNW -25 MNW -35 MNW -55 MNW -80	
4. CHANGE-OVER SWITCH WITH CENTRE OFF - 3 POLE POSITION : I-0-II SWITCHING ANGLE : 60°,45°		NNU -16 NNU -25 NNU -40 NNU -63 NNU -125 NNU-200	
5. CHANGE-OVER SWITCH WITHOUT CENTRE OFF - 3 POLE POSITION : I-II SWITCHING ANGLE : 60°, 45°		NNUD -16 NNUD -25 NNUD -40 NNUD -63 NNUD -125 NNUD-200	
6. STAR - DELTA LOAD SWITCH POSITION : O-Y-△ SWITCHING ANGLE : 60°		NNY -16 NNY -25 NNY -40 NNY -63 NNY -125 NNY-200	
7. STAR-DELTA MOTOR SWITCH WITH SPRING RETURN FROM Y TO △ POSITION : O-Y-△ SWITCHING ANGLE : 60°		MNYR1j-16 MNYR1j-25 MNYR1j-35 MNYR1j-55 MNYR1j-80	
8. POLE CHANGING, TWO SPEED MOTOR SWITCH POSITION : O-I-II SWITCHING ANGLE : 60°, 45°		MNPj-16 MNPj-25	

CONTACT SEQUENCES

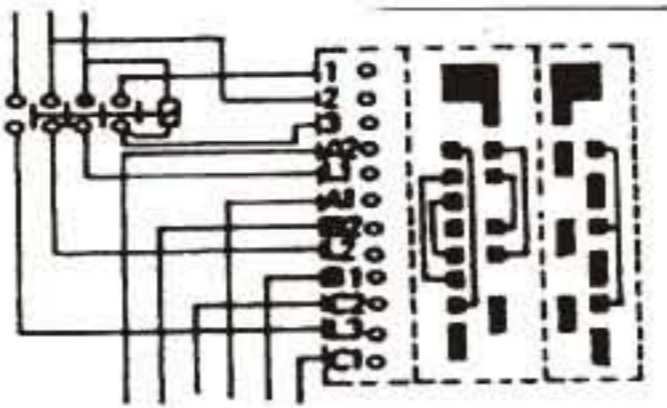
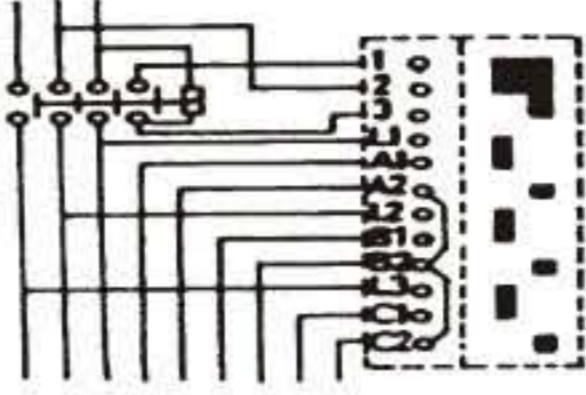
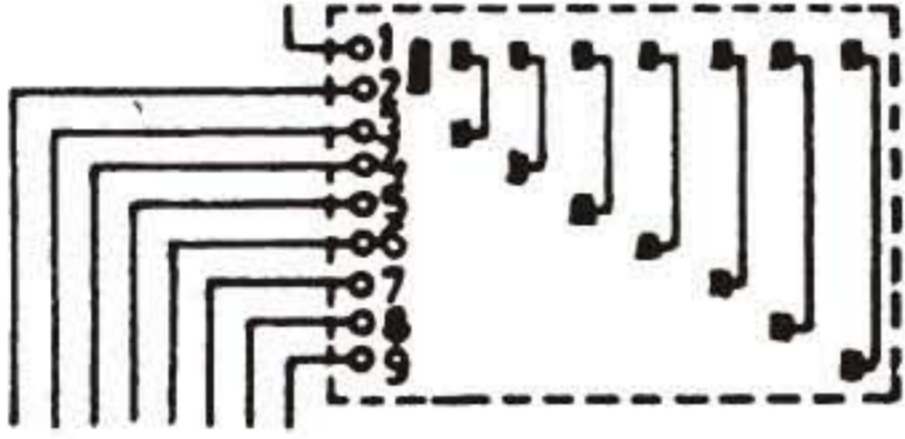
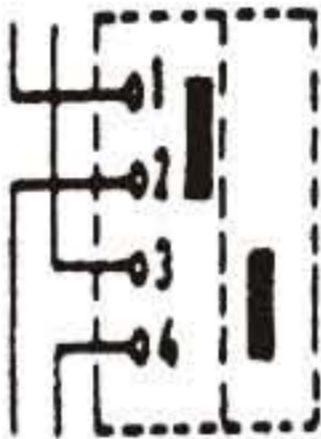
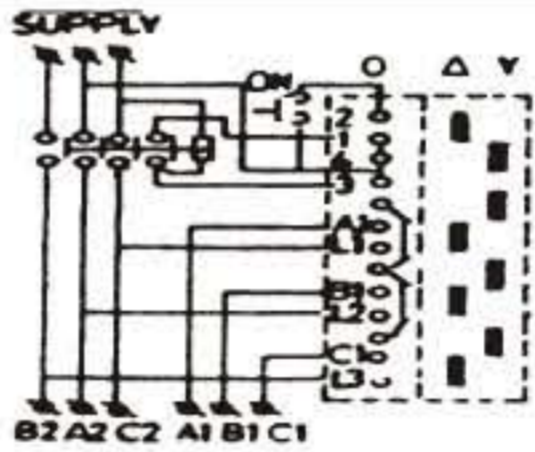
SR. NO.	DESCRIPTION	CONTACT SEQUENCES	TYPE
9.	POLE CHANGING REVERSING, TWO SPEED MOTOR SWITCH POSITION : II-I-O-I-II SWITCHING ANGLE : 45°		MNWPJ-16
10.	AUTO TRANSFORMER STARTER CONTROL SWITCH POSITION : OFF-RUN-START SWITCHING ANGLE : 60°		MNXJD-16 MNXJD-25 MNXJD-40 MNXJD-63 MNXJD-125 MNXJD-200
11.	STEP SWITCH-8 POSITION POSITION : 1,2,3,4,5,6,7,8 SWITCHING ANGLE : 45°		NNU8-16 NNU8-25 NNU8-40
12.	BREAKER CONTROL SWITCH WITH TWO WAY SPRING RETURN POSITION : TRIP NEUTRAL CLOSE SWITCHING ANGLE : 60°		NNU1R2-16 NNU1R2-25
13.	STAR-DELTA MOTOR SWITCH WITHOUT SPRING RETURN POSITION : O Δ Y SWITCHING ANGLE : 60°		MNYJ-16 MNYJ-25 MNYJ-35 MNYJ-55 MNYJ-80

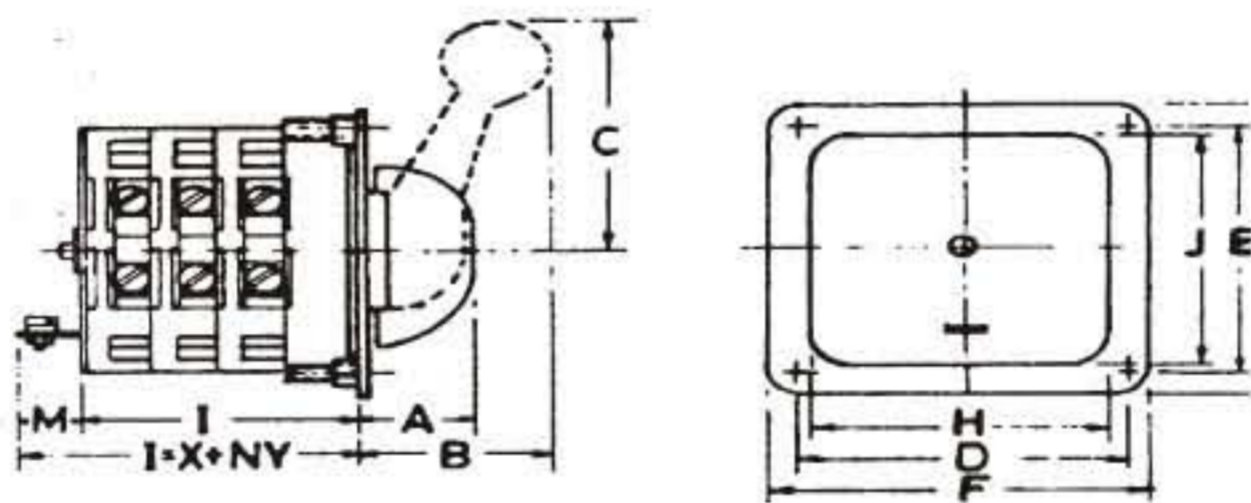

TYPE	A	B		C		D	E	F	G	H	J	M	X	Y
		BAKELITE	METAL	BAKELITE	METAL									
NN-16 *NN-16P MN-16	27.5	46.5		65.5		60	60	74	74	55	55	9.5	27	13
NN-25 MN-25 NN-40 *NN-40P MN-35	30	55	50	76.5	80	80	80	98.5	98.5	81	81	14.5	34	17
NN-63 *NN-63P MN-55	-	66.5	69	105	120	100	100	123	123	108	104	18	39	23
NN-125 MN-80	-	-	84	-	186	158	158	204	204	157	135	-	45	35
NN-200 *NN-200P	-	-	84	-	186	158	204	204	260	135	-	-	-	-

ALL DIMENSIONS IN mm. N : NUMBER OF CONTACT CHAMBERS - SPECIFY PANEL THICKNESS WHILE
* ONE CHAMBER PER ONE POLE

MOUNTING DETAILS

PANEL CUTOUTS FOR MOUNTING

SWITCH TYPES

FLUSH

FRONT

REAR
PANEL

BASE

NN-16
 NN-16P
 MN-16
 NN-25
 MN-25
 NN-40
 NN-40P
 MN-35
 NN-63
 NN-63P
 MN-55
 NN-125
 MN-80
 NN-200
 NN-200P

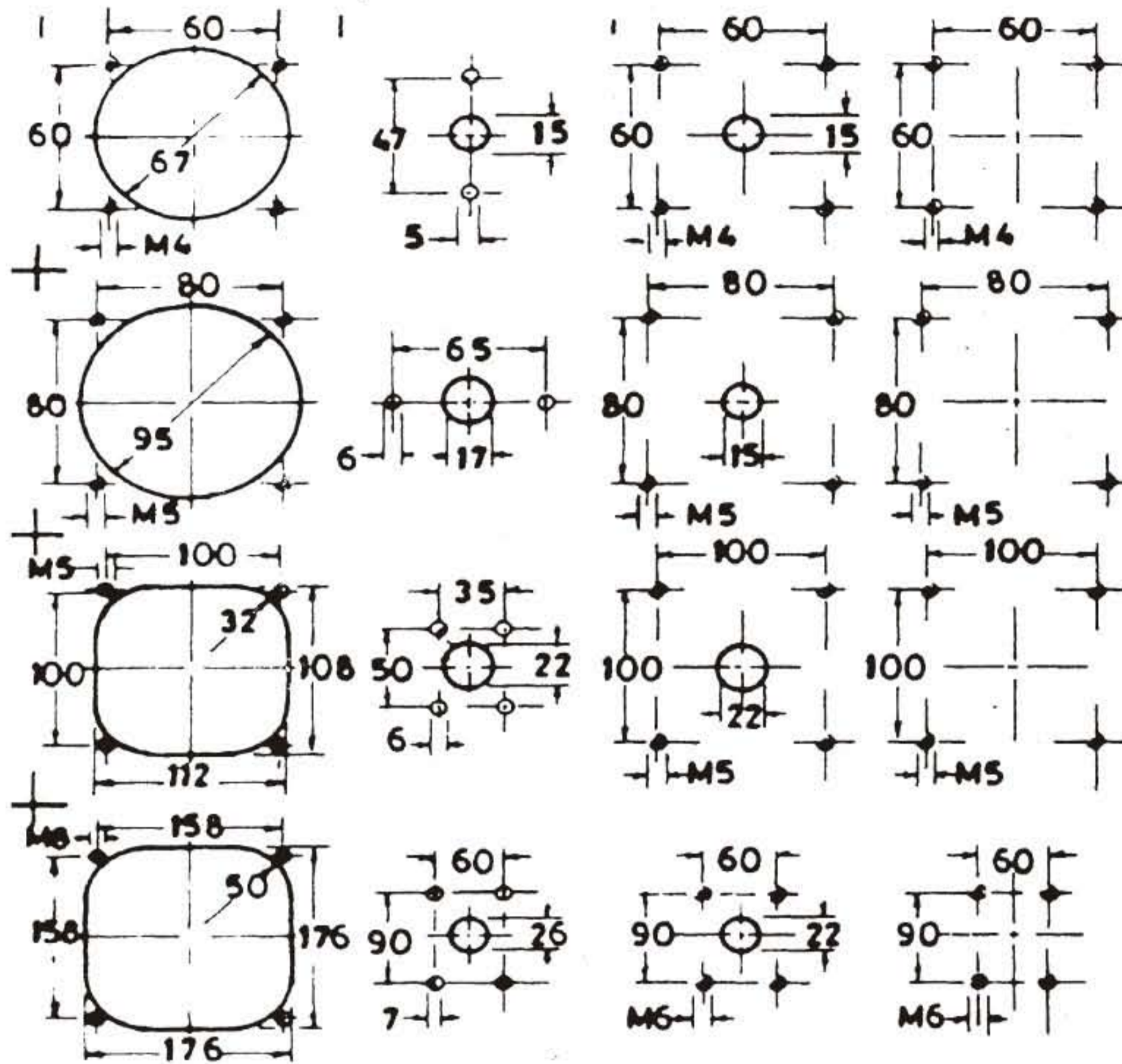

OPTIONAL FEATURE SELECTION

	SWITCH	TYPE		
	NN-16	NN-25	NN-63	NN-125
	NN-16P	MN-25	NN-63P	MN-80
Optional	MN-16	NN-40	MN-55	NN-200
Features		NN-40P		NN-200P
		MN-35		
Rear mounting	✓	✓	✓	✓
Door-cupling and	✓	✓	✓	✓
Door-interlock				
Spring return arrangements	✓	✓	✓	✓
Position locking	✓	✓	✓	
Metal enclosure	✓	✓		